

EcoSEC GPC SYSTEM



ALL-IN-ONE-SYSTEM

INCREASED THROUGHPUT

- Semi-micro (4.6 mm ID) columns cut run time in half, doubling your throughput
- Autosampler for unattended operation
- Stable RI baseline in THF within 2 hours of startup

LOWER SOLVENT COST

- Low dead volume requires 85% less solvent compared to conventional GPC systems
- Superior performance
- Unmatched baseline stability due to unique dual flow RI design
- Excellent retention time reproducibility due to advanced temperature controlled pumps
- Day to day, system to system, location to location consistency

UNPARALLELED VERSATILITY

- Column switching valve
- Easy to use, intuitive software
- Optional UV detector
- Optional Viscometer and Multi-Angle Light Scattering detector
- Optional 3rd party software allows system control, data handling, and connectivity to external detectors and other lab systems

INCREASED THROUGHPUT AND LOWER SOLVENT COSTS

Minimal extra-column band broadening is required to take full advantage of the highest efficiency GPC columns. The EcoSEC GPC System is engineered to minimize system dead volume. The semi-micro design allows the use of GPC columns with smaller ID (4.6 mm) and shorter lengths (15 cm) such as the TSKgel SuperMultiporeHZ columns. Together with a small stroke volume pump and a 2.5 μ L RI flow cell, the EcoSEC GPC System allows accurate and precise molar mass measurements, particularly when benefiting from state-of-the-art column technology.



EcoSEC GPC SYSTEM

TABLE 1

Component	Description	Benefit
SEMI-MICRO DESIGN	The EcoSEC GPC System is engineered for low volume by reduced tubing lengths, low dead volume flow cells, and small stroke pumps.	Maintains the efficiency of semi-micro columns (4.6. mm ID x 15 cm). The result is no loss of resolution at 1/6 the flow rate and 50% of the run time compared to conventional (7.8 mm ID x 30 cm) columns.
CONTROL PANEL	Allows the system to be controlled manually at the discretion of the operator.	Saves time by controlling a series of operations without the use of the computer or software.
AUTOSAMPLER	100 sample capacity, 1 to 1,500 μL per injection.	Automatic sample injection for unattended, around the clock operation.
PURGE UNIT AND DEGASSER	20 and 40 mL solvent volume; variable degassing capacity (for semi-micro or 30 cm column).	Saves time with rapid solvent changes via purge valve eliminating solvent replacement and other time-consuming manual operations.
TEMPERATURE CONTROLLED PUMPS	Pump heads and solvent lines are maintained at a constant temperature.	Improves baseline stability by removing the effect of temperature fluctuations. This results in consistent and accurate flow rates and reproducible molar mass determinations.
COLUMN OVEN	Engineered for precise ($\pm 0.02^\circ\text{C}$) column temperature; oven can accommodate up to 8,30 cm length columns.	Constant column temperature ensures precise and reproducible molar mass determinations.
RI DETECTOR	Low dead volume flow cell, 2.5 μL . Solvent flows through a separate reference cell.	Enhanced baseline stability from dual flow cell RI detector.
UV DETECTOR (optional)	Low dead volume flow cell, 2 μL . Wavelength range from 195-350 nm.	Open for measuring UV-absorbing polymers.
LIGHT SCATTERING DETECTOR (optional)	Up to 7 angle MALS design.	Absolute molar mass determination on the widest range of polymer sizes.
VISCOMETRY DETECTOR (optional)	Unique 80/20 split between sample and reference flow paths.	Reduces run times by up to 50% compared to 50/50 split flow path detectors.



EcoSEC GPC SYSTEM

As shown in Figure 1, when run on the EcoSEC GPC System, the TSKgel SuperMultiporeHZ-N (4.6 mm ID × 15 cm) column achieves separation efficiency equivalent to that of a conventional high-speed column (7.8 mm ID × 30 cm), but analysis time is reduced to half that of a conventional column and one-sixth the amount of solvent is consumed.

The combination of the EcoSEC GPC System and semi-micro columns provides significant solvent related cost savings while doubling sample throughput without compromising resolution. As shown in Table 2, the solvent related cost savings are extraordinary for samples requiring expensive solvents such as hexafluoroisopropanol.

Figure 2 shows an example of an oligomer (A-500) separation using four TSKgel SuperHZ2000 GPC columns in tandem performed using an EcoSEC GPC System and a competitive GPC system. A faster analysis and improved resolution is achieved with the EcoSEC GPC System as a result of the advanced engineering design of the system.

➤ **FIGURE 1**

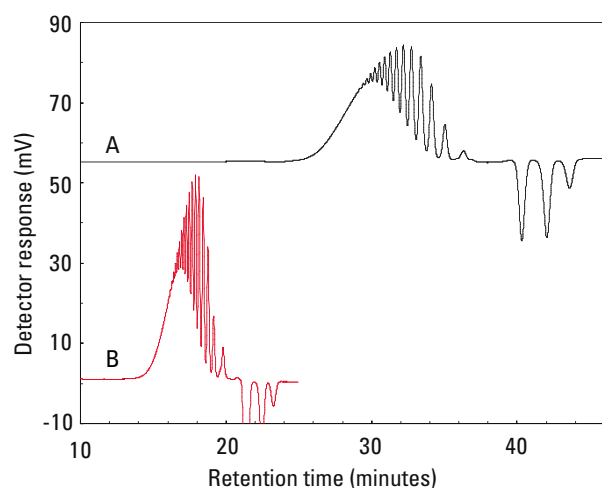

COMPARING SEMI-MICRO AND CONVENTIONAL GPC COLUMNS

Column: A. Conventional column, 7.8 mm ID x 30 cm x 4
 B. TSKgel SuperMultiporeHZ-N, 4.6 mm ID x 15 cm x 4
 Sample: poly(teramethylene ether glycol) (PTMEG 650), 10 µg/µL;
 Mobile phase: THF; Flow rate: A. 1.0 mL/min, B. 0.35 mL/min;
 Detection: RI; Temperature: 40°C; Injection vol.: A. 50 µL, B. 10 µL

➤ **FIGURE 2**

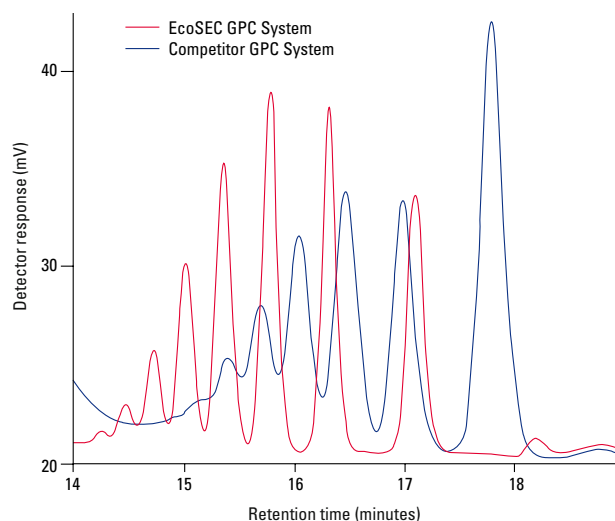

COMPARISON OF RESOLUTION OF A SEMI-MICRO COLUMN RUN ON AN EcoSEC GPC SYSTEM AND A CONVENTIONAL GPC SYSTEM

Column: TSKgel SuperHZ2000, 4.6mm ID x 15 cm x 4; Mobile phase: THF; Flow rate: 0.3 5mL/min; Detection: RI; Temperature: 40°C; Injection vol.: 10 µL; Sample: styrene oligomer (A-500), 0.2 mg/mL

➤ **TABLE 2**

ANNUAL SOLVENT COST SAVING WITH SEMI-MICRO COLUMNS AND THE EcoSEC GPC SYSTEM

Solvent	Competitive GPC System	EcoSEC GPC System	Savings
THF cost (€ 30/L)/year	3.600	1.188	2.376
THF disposal cost (€ 30/L)/year	3.600	1.188	2.376
HFIP* cost (€ 1.500/L)/year	180.000	59.400	120.600
HFIP disposal cost (€ 60/L)/year	7.200	2.376	4.824

* THF: tetrahydrofuran; HFIP: hexafluoroisopropanol



EcoSEC GPC SYSTEM

SUPERIOR PERFORMANCE

UNMATCHED BASELINE STABILITY

REFRACTOMETER

- Dual flow cell design
- Continuous correction of RI baseline drift due to solvent instability
- Improved molar mass precision and accuracy
- Rapid baseline stability at startup

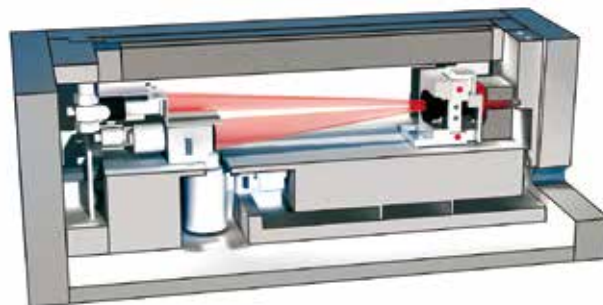

BASIC PRINCIPLE OF REFRACTIVE INDEX DETECTION

The most common type of differential refractive index detector is a deflection-type detector employing the principles of Snell's law of refraction. In this type of detector, light emitted from a source is transmitted through the flow cell of the RI detector and strikes a detector element. The flow cell is constructed in such a way that there are two separate, triangular pyramid shaped compartments (sides): (1) the reference side, consisting of stagnant pure solvent; and (2) the sample side, containing a flowing stream of analyte in the same solvent as in the reference side. As the light passes through the reference side into the sample side, the direction in which the light is travelling is changed, e.g., the path is bent. The amount of bending that takes place depends on the nature of the flow cell, the wavelength of the light being used, and the temperature and the concentration of analytes in the cell.

The light then strikes a mirror and reflects back through the cell to two photodiodes mounted on a single chip. The two photodiodes will produce equal signals if the contents of the reference and sample sides have the same refractive indices as each other (Figure 3). In contrast, if the reference and sample sides have different refractive indices, a voltage difference will result between the photodiodes because the two photodiodes detect the difference in light intensity due to the bending of the light beam, as shown in Figure 4. The difference in refractive indices between the two sides produces a voltage difference proportional to the concentration of the analyte in solution.

➤ **FIGURE 3**

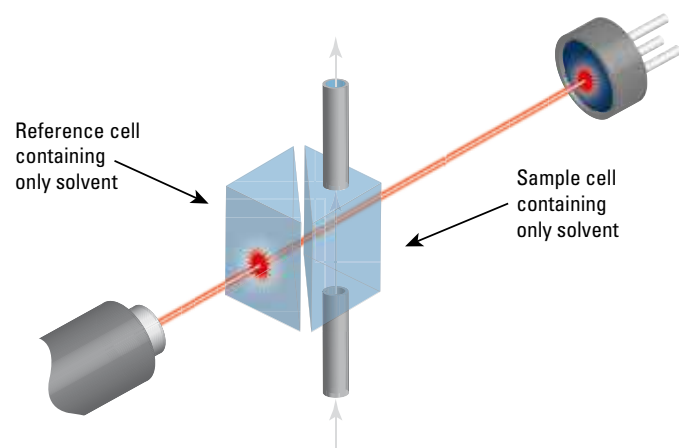

DEPICTION OF RI DETECTOR FLOW CELL WHEN THE CONTENTS OF THE REFERENCE AND SAMPLE SIDES HAVE THE SAME REFRACTIVE INDICES AS EACH OTHER

➤ **FIGURE 4**

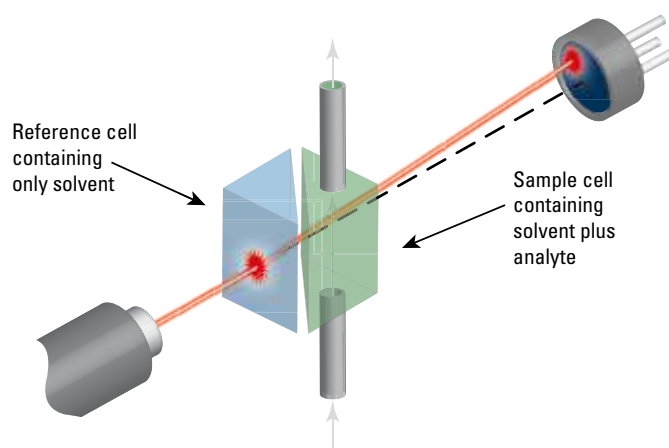

DEPICTION OF RI DETECTOR FLOW CELL WHEN THE CONTENTS OF THE REFERENCE AND SAMPLE SIDES HAVE DIFFERENT REFRACTIVE INDICES

EcoSEC GPC SYSTEM



DUAL FLOW REFRACTIVE INDEX DETECTOR

The refractive index detector in the EcoSEC GPC System is unlike any other refractive index detector on the market due to its unique dual flow design. The EcoSEC GPC System RI flow cell is constructed in such a way that there are two sides: (1) the reference side, containing a flowing stream of pure solvent; and (2) a sample side, containing a flowing stream of analyte in the same solvent as in the reference side (Figure 5).

The unique dual flow design of the EcoSEC GPC System results in superb RI baseline stability and reduced RI baseline drift. In a conventional RI detector, over time, the refractive index of the stagnant pure solvent in the reference side will slowly change and the two photodiodes will no longer produce equal signals, thus the contents of the reference and sample sides have different refractive indices and will produce a voltage difference similar to that of an analyte in solution. For example, the refractive index of THF slowly alters over time, due to the buildup of peroxide-related compounds, resulting in baseline drift (Figure 6). The dual flow design of the RI detector in the EcoSEC GPC System compensates for the changes in refractive index of the solvent over time by continuously flowing pure solvent through the reference side of the flow cell.

Another benefit of the dual flow cell is rapid attainment of baseline stability when the instrument is first started, as purging is not required. A stable baseline can be achieved by flowing only 50 mL of solvent through the instrument. Additionally, the reference side mobile phase can be sent to waste or recycled back to the solvent bottle.

The EcoSEC GPC System offers unmatched baseline stability because it is the only GPC system which uses a dual flow refractive index detector and temperature controlled pumps. Baseline stability is essential for the accurate calculation of polymer molar mass averages. For example, computer simulations predict a polymer with a polydispersity index (PDI) of 5 will have an 18% error for M_z if baseline instability leads to a 4% error in peak width determination. In addition, a 2% uncertainty in baseline height will result in a 20% error in M_z ¹.

¹Tcjr, W.J.; Rudin, A.; and Fyfe, C.A.; Journal of Polymer Science: Polymer Physics Edition, Volume 20, Issue 8, 1443-1451

➤ FIGURE 5

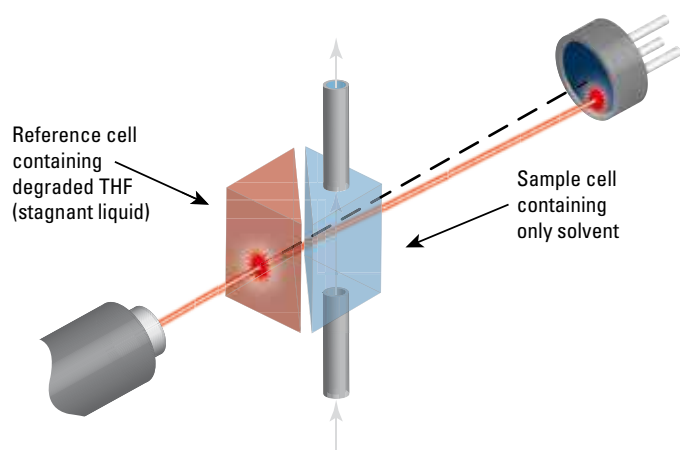

➤ FIGURE 6

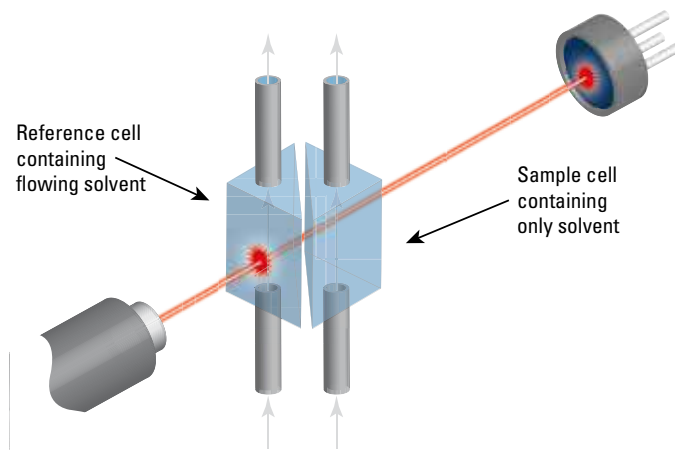

DEPICTION OF DUAL FLOW RI DETECTOR IN THE EcoSEC SYSTEM, SHOWING THE COMPENSATION OF THE CHANGES IN REFRACTIVE INDEX OF THE SOLVENT OVER TIME

DEPICTION OF RI DETECTOR FLOW CELL SHOWING THE EFFECTS OF THF DEGRADATION IN THE STAGNANT REFERENCE SIDE OF A CONVENTIONAL GPC SYSTEM



EcoSEC GPC SYSTEM

A study was done to demonstrate the superb baseline stability of the EcoSEC GPC System compared to that of two conventional GPC systems over a five hour time period. As shown in Figure 7, five consecutive injections of polystyrene standards with run times deliberately extended to one hour without auto zeroing the detectors between injections, resulted in an extremely stable baseline with low baseline drift on the EcoSEC GPC System and a significantly drifting baseline on the two conventional GPC systems. In comparison to the conventional GPC systems, the EcoSEC GPC System has both a lower baseline drift and a better signal to noise ratio.

COMPARISON OF BASELINE STABILITY

Five injections of dicyclohexyl phthalate were made on the EcoSEC GPC System and a conventional GPC instrument with a stagnant reference cell. The chromatograms were overlaid and are shown in Figures 8A and 8B.

With the EcoSEC GPC System, superposition of five consecutive chromatograms shows negligible baseline drift, as compared to the same experiment repeated with a competitor's GPC system having a non flow-through reference cell.

FIGURE 7

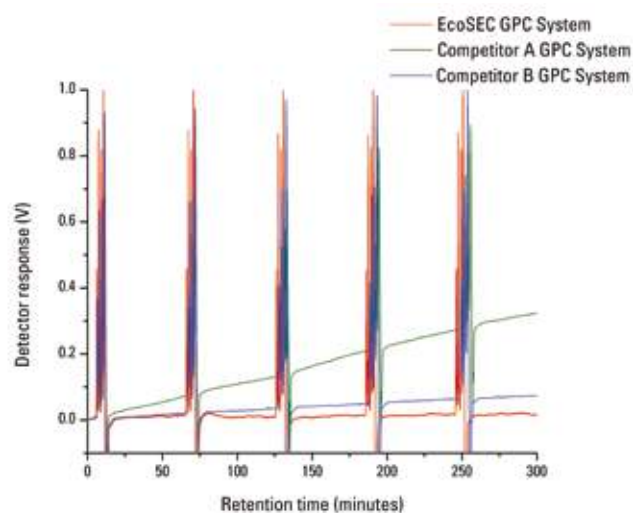

COMPARISON OF BASELINE DRIFT OF THE DUAL FLOW REFRACTIVE INDEX DETECTOR OF THE EcoSEC GPC SYSTEM AND TWO CONVENTIONAL GPC SYSTEMS

Column: TSKgel SuperMultiporeHZ-M, 4.6 mm ID x 15 cm x 2; Sample: polystyrene standards, PStQuick MP-M series; Mobile phase: THF; Flow rate: 0.35 mL/min; Detection: RI; Temperature: 40°C; Injection volume: 10 μ L

FIGURE 8

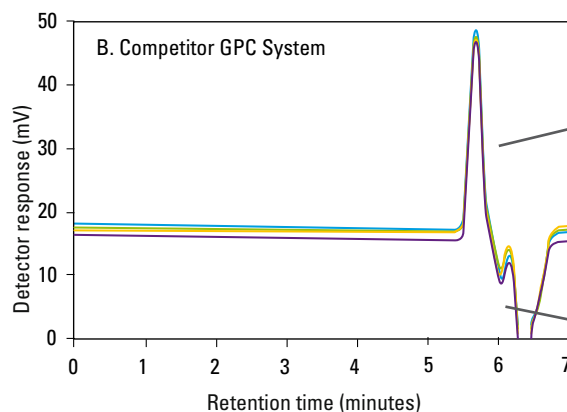
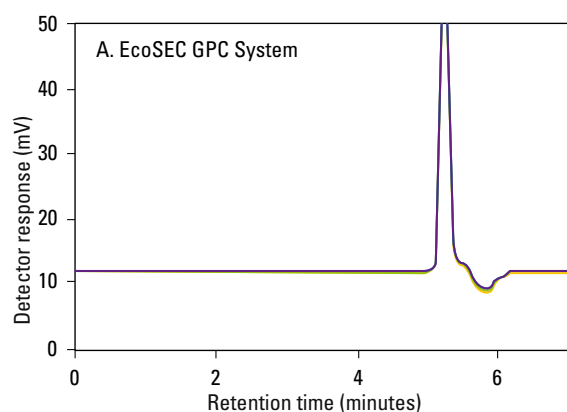

COMPARISON OF BASELINE STABILITY

Column: TSKgel SuperMultiporeHZ-M, 4.6 mm ID x 15 cm; Sample: dicyclohexyl phthalate; Mobile phase: THF; Flow rate: 0.35 mL/min; Detection: RI; Temperature: 40°C; Inj. volume: 10 μ L

EcoSEC GPC SYSTEM



COMPREHENSIVE TEMPERATURE CONTROL

ELUTION TIME PRECISION

To assess the influence of environmental conditions within the laboratory on solvent flow, a study was done in which the EcoSEC GPC System and a conventional GPC system were placed in a chamber where the temperature was cycled between 23°C and 26°C. A series of sixty injections of polystyrene were made over a time period of ten hours. For each instrument the elution volume at peak maximum was measured; the resulting data is shown in Figure 9 below. The elution volume drift of the EcoSEC GPC System was about 20% lower than that of the conventional GPC system.

The results shown demonstrate that the engineering design concepts of the EcoSEC GPC System result in a high degree of reproducibility of elution times and molar mass determinations.

M_w PRECISION

Molar mass averages can be affected by changes in the environment and measuring conditions. Generally, these variations are the result of one or more factors including flow rate reproducibility, baseline drift and injection reproducibility. In addition to controlling column temperature, Tosoh engineers added temperature control for both pumps and inlet and outlet tubing on the EcoSEC GPC System to deliver top GPC analysis performance.

FIGURE 9

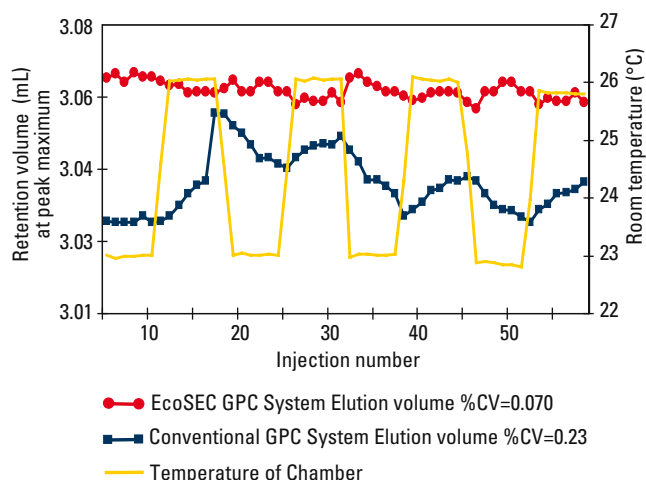
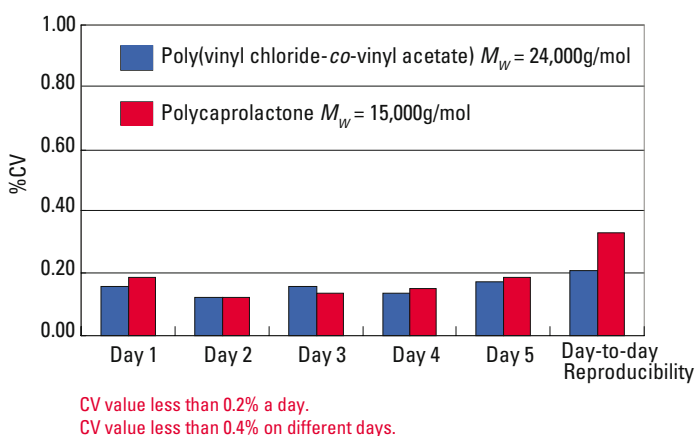

Figure 10 demonstrates the superiority of the EcoSEC GPC System for the determination of weight average molar masses. Figure 11 shows a comparison of M_w reproducibility for a sample injected 10 times a day for 5 days on the EcoSEC GPC System compared to a conventional GPC. The reproducibility of the EcoSEC GPC System was superior by a factor of 3 to that of the conventional GPC system.

FIGURE 10



REPRODUCIBILITY OF M_w ANALYSIS

Column: TSKgel SuperMultiporeHZ-M, 4.6 mm ID x 15 cm x 2; Sample: poly (vinyl chloride-co-vinyl acetate); Mobile phase: THF; Flow rate: 0.35 mL/min ; Temp.: 40 °C; Detection: RI; Inj.volume: 10 µL

FIGURE 11

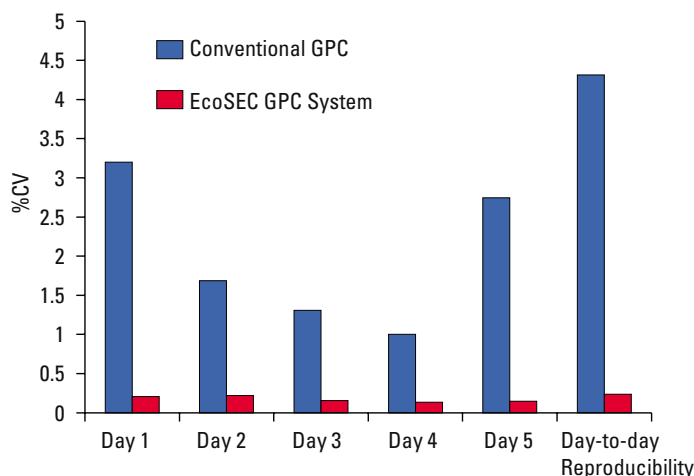

COMPARING M_w REPRODUCIBILITY OF THE EcoSEC GPC SYSTEM AND A CONVENTIONAL GPC SYSTEM

Column: TSKgel SuperMultiporeHZ-M, 4.6 mm ID x 15 cm x 2; Sample: poly (vinyl chloride-co-vinyl acetate); Mobile phase: THF; Flow rate: 0.35 mL/min ; Temp.: 40 °C; Detection: RI; Inj.volume: 10 µL

MOBILE PHASE DELIVERY REPRODUCIBILITY WITH AMBIENT TEMPERATURE CHANGES

Column: TSKgel SuperMultiporeHZ-M, 4.6 mm ID x 15 cm x 2; Sample: polystyrene standard; Mobile phase: THF; Flow rate: 0.35 mL/min, Detection: RI; Temperature: 40°C; Inj.volume: 10 µL Temperature was cycled 23°C-26°C in the testing chamber.



EcoSEC GPC SYSTEM

SYSTEM-TO-SYSTEM REPRODUCIBILITY

Often measurements can be reproduced using the same equipment but results differ when an instrument from the same or another manufacturer is used. Among the system-specific factors which can influence the results of GPC analysis, fluctuations in elution time, in particular, can have a significant effect.

A study was performed using a polydisperse poly(vinyl chloride-co-vinyl acetate) sample run on four different EcoSEC GPC Systems by different operators to assess system reproducibility. The results are shown in Figure 12. The high-precision of the EcoSEC GPC System results in minimal variation among instruments and from day-to-day.

SITE-TO-SITE REPRODUCIBILITY

To test site reliability, a round-robin study was undertaken in which the same polydisperse poly(vinyl chloride-co-vinyl acetate) sample was run on EcoSEC GPC Systems located at four different sites. The results are displayed in Table 3.

Reproducibility from system-to-system and location-to-location is exceptional with the EcoSEC GPC System. Coefficients of variations for all mass determinations were all well below 1%. Because of the high instrument-to-instrument reproducibility of the EcoSEC GPC System, methods developed at one location, e.g., an R&D laboratory, can be reliably transferred to a second site, e.g., a QC lab at a manufacturing site, and so on.

TABLE 3

SITE-TO-SITE REPRODUCIBILITY

	M_n	M_w	W_z
Site A	13,800	29,800	53,700
Site B	13,700	29,900	54,300
Site C	13,600	29,800	53,200
Site D	13,700	30,200	54,100
Average	13,700	29,900	53,800
Deviation	70	160	420
%CV	0.52	0.55	0.78

For EcoSEC GPC Systems, 4 operators, 4 column sets, 4 conditions, 4 locations

Column: TSKgel SuperMultiporeHZ-M, 4.6 mm ID x 15 cm x 2; Sample: poly (vinyl chloride-co-vinyl-acetate); Mobile phase: THF; Flow rate: 0.35 mL/min, Detection: RI; Temperature: 40°C; Inj.volume: 10 µL

Average of values measured with each instrument (n=10).

FIGURE 12

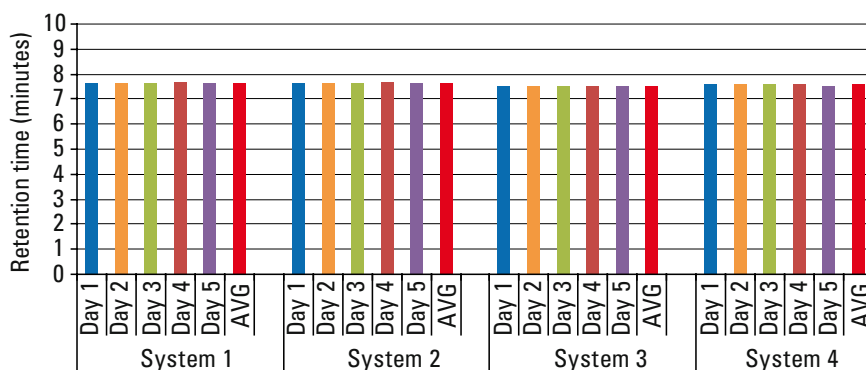

Four EcoSEC GPC Systems, 4 operators, 4 column sets, 4 conditions, one location

DAY-TO-DAY REPRODUCIBILITY

Column: TSKgel SuperMultiporeHZ-M, 4.6 mm ID x 15 cm x 2; Sample: poly (vinyl chloride-co-vinyl acetate); Mobile phase: THF; Flow rate: 0.35 mL/min ; Temp.: 40 °C; Detection: RI; Inj.volume: 10 µL

EcoSEC GPC SYSTEM



RAPID COLUMN SWITCHING

COLUMN SWITCHING VALVE

- Reduce column switching time
- Easily switch between low MM and high MM range columns
- Eliminate temperature related baseline drift following column change



The EcoSEC GPC System contains two pumps: a sample pump to deliver sample and solvent through the analytical column and the sample side of the RI detector flow cell and a reference pump to flow solvent (via a reference column) to the reference side of the RI detector flow cell. By installing an optional column switching valve and replacing the reference column with another analytical column, an analysis can be performed on column 1 while equilibrating column 2. After switching the valve, column 2 becomes the measurement column while column 1 will be in the flow path to the reference side of the RI detector flow cell.

Since the column switching valve changes column sets while the oven door remains closed and switches to an already equilibrated column set, a stable baseline is rapidly established.

➤ FIGURE 13

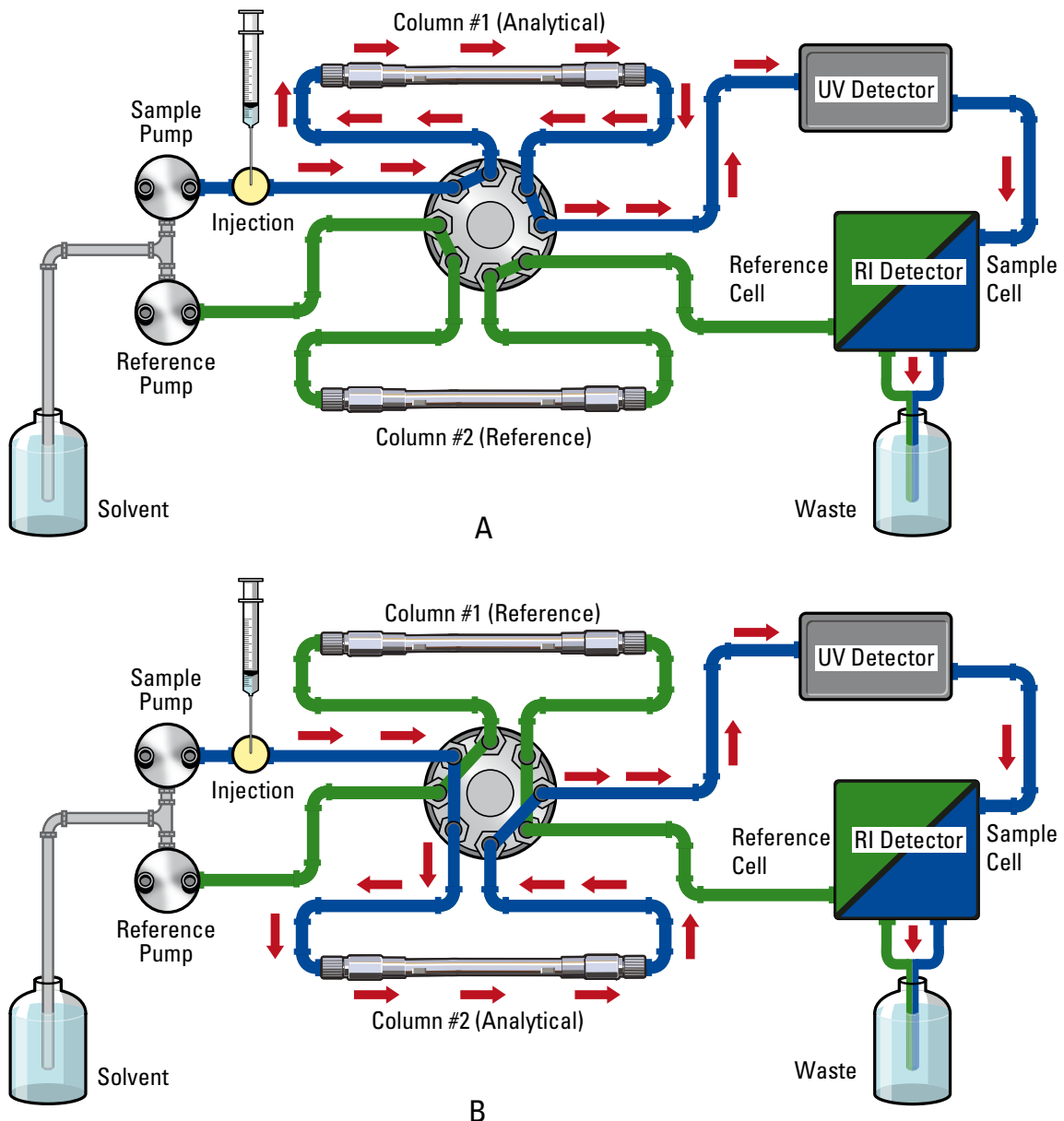

A.) FLOW PATH WITH COLUMN 1 AS THE ANALYTICAL COLUMN B.) FLOW PATH WITH COLUMNS 2 AS THE ANALYTICAL COLUMN



EcoSEC GPC SYSTEM

COMPARISON OF TIME TO BASELINE STABILITY WITH AND WITHOUT THE COLUMN SWITCHING VALVE

On the EcoSEC GPC System the RI baseline is considered stabilized when the drift in signal is 1×10^{-7} RIU/hr or less (based on THF at a flow rate of 1.0 mL/min). When a new set of columns is manually placed on the EcoSEC GPC System and the flow rate is started, the RI baseline stabilizes after 80 - 90 minutes. When a new column set is brought online using the column switching valve, the baseline stabilizes after 15 minutes.

(Experimental conditions: THF, 35°C, 0.35 mL/min, 20 minute warm-up at 50% flow rate). Figure 14 clearly demonstrates the 65 – 75 minute savings in time required to reach a stable baseline when the columns are switched using the column switching valve compared to manually changing columns.

FIGURE 14

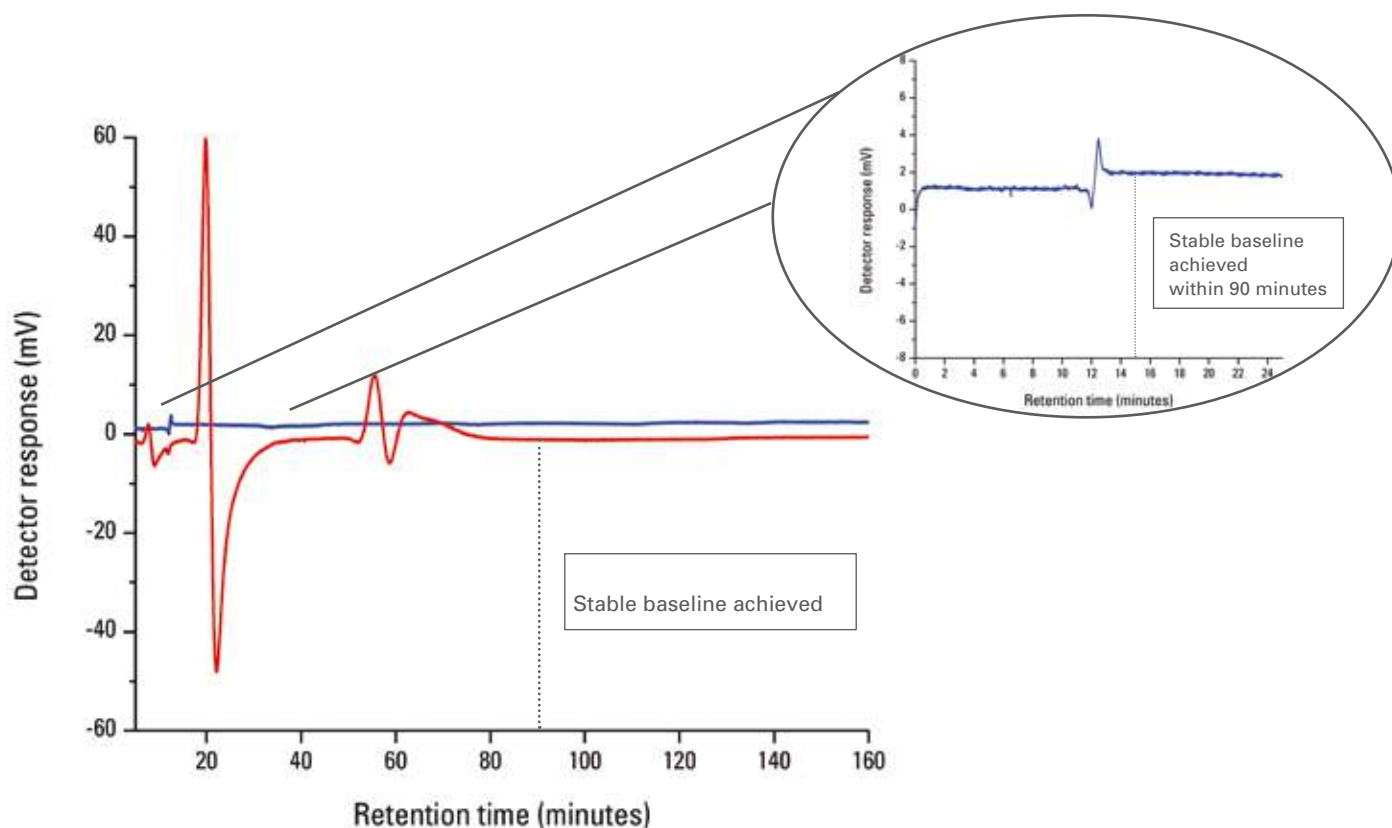

OVERLAY OF REFRACTIVE INDEX DETECTOR SIGNALS DURING EQUILIBRATION FOLLOWING A COLUMN CHANGE USING THE COLUMN SWITCHING VALVE (BLUE) AND WITHOUT USE OF THE COLUMNS SWITCHING VALVE (RED)

CONFIGURATION OPTIONS



UV DETECTOR

- Variable UV; 195 – 350 nm
- Semi-micro flow cell (2 μ L)
- Factory installed option

The optional UV detector is variable from 195 to 350 nm and the detector flow path and electronics are optimized for the use of semi-micro columns. The volume of the flow cell is reduced to 2 μ L and the shortest time constant is 0.5 seconds.

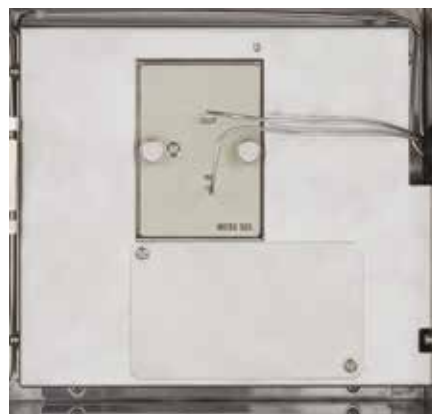

COPOLYMER ANALYSIS

The EcoSEC GPC System equipped with both RI and UV detectors can be used to determine the structural composition of an unknown copolymer, in which the copolymer contains one UV visible and one non-UV visible component. At least one copolymer of known composition must be available to create a copolymer calibration curve. The final result is a plot of the structural composition at each molar mass. This composition curve overlaid on the chromatogram, as seen in Figure 15, can be generated using the EcoSEC GPC Workstation Software. The software allows for the creation and use of separate UV and RI specific calibration curves while correcting for the inter detector delay volume.

➤ **FIGURE 15**

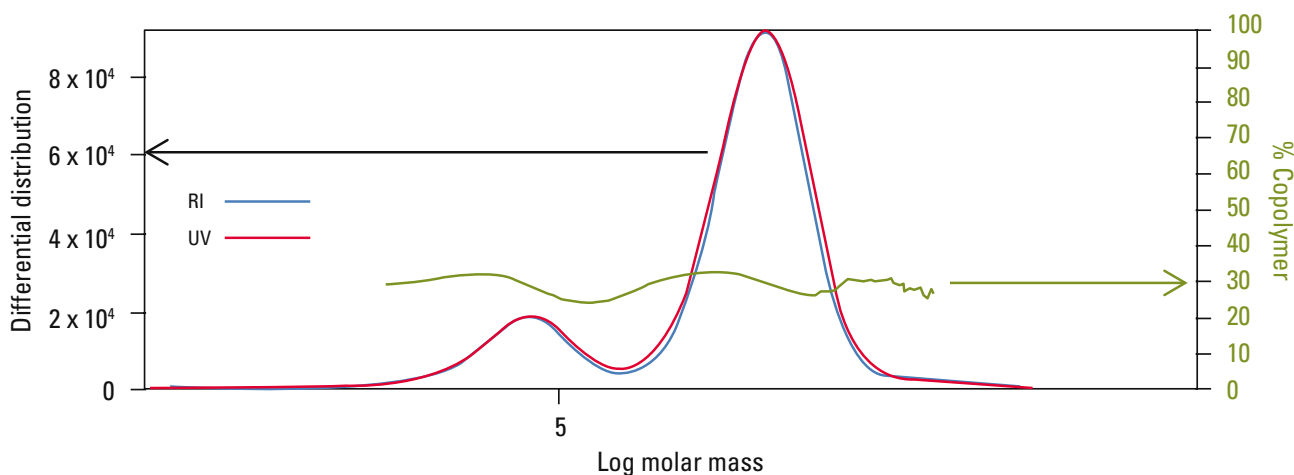

COPOLYMER ANALYSIS OF POLYSTYRENE-b-POLYBUTENE

Column: TSKgel SuperMultiporeHZ-M, 4.6 mm ID x 15 cm x 2; Mobile phase: THF; Flow rate: 0.35 mL/min, Detection: RI, UV@254 nm; Temperature: 40°C; Injection vol.: 10 μ L; Samples: PS-b-PB, 0.2 wt%



CONFIGURATION OPTIONS

TABLE 4
UV DETECTOR SPECIFICATIONS

UV DETECTOR	SPECIFICATION
System	Dual beam, single flow cell
Light source	Deuterium lamp
Wavelength range	195 to 350 nm
Wavelength accuracy	± 2 nm
Bandwidth	8 nm
Range (FS)	0.5, 1, 2, 4 AU/1 V
Response	0.5, 1.0, 3.0 seconds
Drift	3×10^{-4} AU/h (254 nm, air in cell, response: 1.0 s)
Noise	2.5×10^{-5} AU/h (254 nm, air in cell, response: 1.0 s)
Flow cell volume	2 μ L
Safety mechanism	Liquid leakage sensor; lighting time monitoring

EcoSEC GPC SYSTEM



► ECOSEC SPECIFICATIONS

PUMP

SPECIFICATION

Flow rate	0.010 to 2.000 mL/min in 0.001 mL/min steps
Accuracy	+/- 2%
Precision	+/- 0.2%
Maximum pressure	25 MPa or 3,500 psi
Safety features	Liquid supply stops if pressure rises above the upper limit or drops below the lower limit, Plunger drive count monitoring, Pan for liquid leakage
Stroke volume	7.51 μ L

AUTO-INJECTOR

Injection volume	1 to 1,500 μ L in 1 μ L increments
Number of samples	Air detection in wash solution and sample solution, Needle lock when the sample table is not loaded, Monitoring of 6-way and 4-way valve rotations

COLUMN OVEN

Temperature range	Ambient plus 10°C to 60°C
Capacity	7.8 mm ID x 30 cm x 8 columns
Accuracy	+/- 0.5°C
Precision	+/- 0.2°C

RI DETECTOR

Type	Bryce or dual flow type, Tungsten light source (1.00-1.80 RI range)
Optics	Deflection
Cell volume	2.5 μ L
Cell pressure limit	0.5 MPa
Noise	2×10^{-9} RI units (RIU)
Drift	1×10^{-7} RIU/h (THF, 1.0 mL/min)
Dynamic range	+/- 2.5×10^{-4} RIU
Temperature control	Off, 35°C, 40°C, 45°C
Analog out	For connection to third party light scattering and viscometry detectors
Safety features	Leak sensor and thermal fuse for circuit block

INSTRUMENT

Dimensions	680 (W) x 500 (D) x 550 (H) mm = 2.2' x 1.6' x 1.8'
Weight	95 kg = 210 lbs



APPLICATIONS

HFIP REPRODUCIBILITY

Dr. Li Jia and co-workers at the University of Akron are investigating different synthetic routes for the formation of polypeptides with alternating block structures. Highly reproducible data is needed to obtain subtle molar mass distribution trends from the various synthetic routes. The EcoSEC GPC System and a set of TSKgel mixed-bed columns were used successfully to obtain high quality molar mass distribution (MMD) data of a series of Dr. Jia's block poly- β -alkylalanoids with hexafluoroisopropanol (HFIP) as the mobile phase in under 15 minutes.

As shown in Table 5, percent standard deviations are more than 10 x lower than values previously reported for polyamides in HFIP².

Percent relative standard deviation of the polydispersity index (PDI) ranged from 0.1 to 0.5%, permitting one to report PDIs within three significant figures. The high precision of the EcoSEC GPC System allows for the detailed study of polymerization reactions.

Sample chromatograms from 4 selected poly- β -alkylalanoid samples run on an EcoSEC GPC System using two TSKgel GMH_{HR}-M, 5 μ m, 4.6 mm ID x 15 cm columns are shown in Figure 16. Sample profiles display very little tailing and no baseline drift, allowing for highly precise data not available with conventional systems. All samples, with the exception of (C)₄₀, contain almost symmetrical, narrow polymer profiles eluting around 6 minutes. The shoulder seen in (C)₄₀ is indicative of another population of a high MW polymer component in the sample.

➤ **TABLE 5**

AVERAGED VALUES FROM THREE CONSECUTIVE INJECTIONS AND THE PERCENT RELATIVE STANDARD DEVIATIONS

Sample ^a	M_n^b		M_w^b		PDI ^b	
		Rel std dev		Rel std dev		Rel std dev
(A) ₁₀ (B) ₄₀	26,500 \pm 10	0.04%	30,300 \pm 30	0.11%	1.14 \pm 0.01	0.09%
(A) ₆₀ (B) ₂₀	33,300 \pm 170	0.52%	40,700 \pm 28	0.07%	1.22 \pm 0.01	0.50%
(A) ₄₀ (B) ₄₀	48,700 \pm 220	0.45%	60,900 \pm 160	0.26%	1.25 \pm 0.01	0.10%
(C) ₄₀	30,100 \pm 50	0.18%	36,400 \pm 140	0.37%	1.21 \pm 0.01	0.39%

^a. Block lengths were determined by Dr. Jia from independent measurements. Chemical composition of blocks A, B and C will be published by L. Jia.

^b. Molar mass data were obtained from a PMMA calibration curve. Molar mass averages given in the table are averages of three sequential injections per sample. Based on block lengths, MMD are significantly overestimated.

➤ **FIGURE 16**

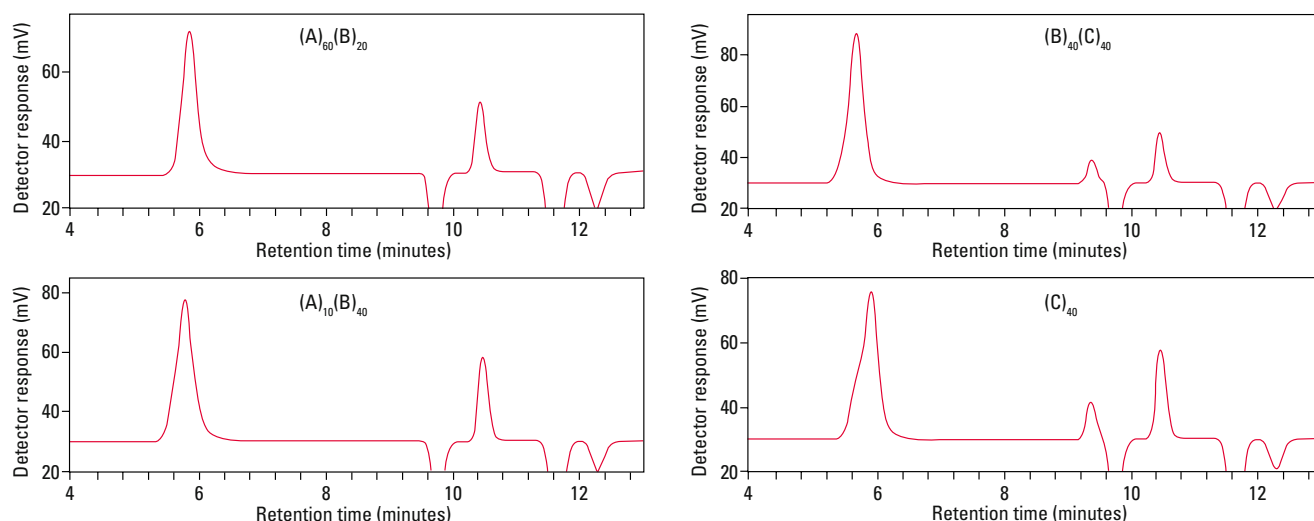

POLY- β -ALKYLALANOID SAMPLES

TSKgel GMH_{HR}-M, 5 μ m, 4.6 mm ID x 15 cm x 2 packed in HFIP; Samples: selection of poly- β -alkylalanoid samples

Mobile Phase: HFIP containing 5 mmol/L sodium trifluoroacetate; Flow rate: 0.35 mL/min; Detection: RI; Temperature: 40°C Inj. vol.: 10 μ L

APPLICATIONS



MODIFIED POLYURETHANE PREPOLYMER ANALYSIS

An EcoSEC GPC System was used to analyze an isocyanate modified polyurethane prepolymer with residual DMSO. As shown in Figure 17, separation of the sample by GPC results in ten positive chromatographic peaks and two negative chromatographic peaks. The first nine chromatographic peaks correspond to components of the modified polyurethane prepolymer while the two negative chromatographic peaks are indicative of the solvent, THF. The latest eluting peak is a result of the residual DMSO present in the sample and is retained by a non-SEC retention mechanism, as it elutes after the void volume of the column.

The molar mass averages M_n , M_w , and M_z of the sample, given in Table 6, were determined via a polystyrene relative calibration curve. The sample was found to have a weight average molar mass M_w ranging from 4,199 to 178 g/mol. The polydispersity index (PDI) shown in Table 6 for the entire sample, e.g., peaks 1 through 9, was 2.26 while the individual components of the polyurethane prepolymer had PDI values ranging from 1.01 to 1.09. From the PDI values it can be concluded that collectively the sample is polydispersed with respect to molar mass, but the nine visible components within the sample are virtually monodispersed with respect to molar mass.

FIGURE 17

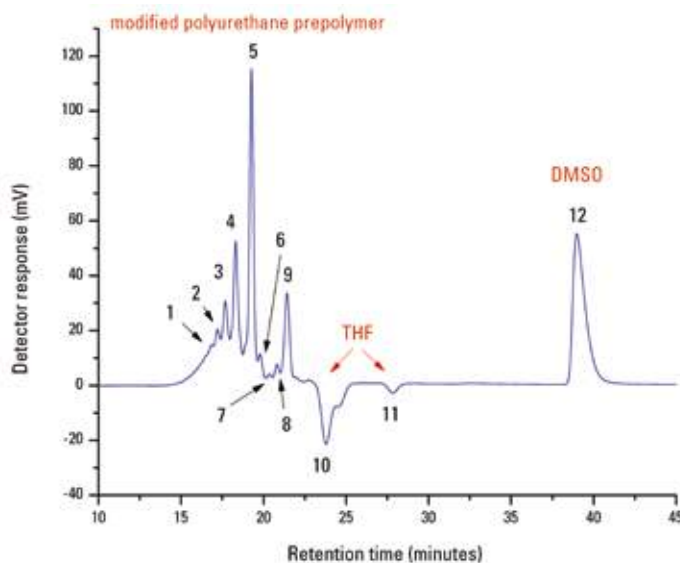

MODIFIED POLYURETHANE PREPOLYMER SAMPLE

Column: TSKgel SuperH3000, 6.0 mm ID x 15 cm x 2; Sample: modified polyurethane prepolymer, 10 mg/mL; Mobile phase: THF; Flow rate: 0.30 mL/min; Detector: RI; Temperature: 35°C; Injection volume: 20 μ L

TABLE 6

MOLAR MASS AVERAGES AND POLYDISPERSITY INDEX FOR MODIFIED POLYURETHANE PREPOLYMER SAMPLE IN THF AT 0.3 mL/min

Peak	M_n	M_w	M_z	PDI ^a
1	4,199 \pm 46 ^b	4,606 \pm 67	5,214 \pm 109	1.09 \pm 0.01
2	2,643 \pm 19	2,655 \pm 18	2,667 \pm 18	1.01 \pm 0.01
3	2,011 \pm 16	2,024 \pm 16	2,038 \pm 16	1.01 \pm 0.01
4	1,387 \pm 10	1,403 \pm 10	1,418 \pm 10	1.01 \pm 0.01
5	798 \pm 4	808 \pm 5	817 \pm 5	1.01 \pm 0.01
6	551 \pm 9	554 \pm 9	557 \pm 9	1.01 \pm 0.01
7	391 \pm 9	394 \pm 9	397 \pm 10	1.01 \pm 0.01
8	278 \pm 3	280 \pm 3	282 \pm 3	1.01 \pm 0.01
9	178 \pm 1	181 \pm 1	183 \pm 1	1.01 \pm 0.01
All	676 \pm 9	1,531 \pm 31	2,873 \pm 83	2.26 \pm 0.02

^a PDI = M_w/M_n

^b Standard deviations from six injections



APPLICATIONS

ANALYSIS OF STYRENE AND ISOPRENE BLOCK COPOLYMERS BEFORE AND AFTER FLUORINATION

Dr. Jimmy Mays' group from the Department of Chemistry at the University of Tennessee, Knoxville, is synthesizing and characterizing the bulk morphology of fluorinated and sulfonated block copolymers. Well-defined block copolymers of sulfonated polystyrene-*b*-fluorinated polyisoprene (sPS-*b*-fPI), Figure 18, were synthesized by anionic polymerization followed by fluorination and sulfonation³.

The EcoSEC GPC System, equipped with TSKgel SuperMultipore[®] columns, was then used to determine the number-average molar mass, M_n , and the polydispersity index, PDI, of sPS-*b*-fPI, as well as that of the precursor polymer (PS-*b*-PI), Table 7. As seen in Figure 19, complete analysis of sPS-*b*-fPI was obtained in less than 10 minutes with excellent resolution using the EcoSEC GPC System.

➤ FIGURE 18

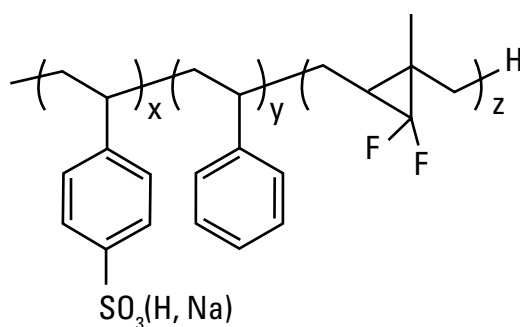

➤ TABLE 7

NUMBER-AVERAGE MOLAR MASS, M_n , AND THE POLYDISPERSITY INDEX (PDI) OF sPS-*b*-fPI AND THE PRECURSOR POLYMER (PS-*b*-PI)

Series ^a	PS- <i>b</i> -PI		sPS- <i>b</i> -fPI	
	M_n (SEC)	PDI	M_n (SEC)	PDI
1	2.1×10^4	1.04	2.5×10^4	1.08
2	4.6×10^4	1.03	6.0×10^4	1.05

^a series 1 in acid form; series 2 in Na form

STRUCTURE OF SULFONATED POLYSTYRENE-*b*-FLUORINATED POLYISOPRENE (sPS-*b*-fPI)

➤ FIGURE 19

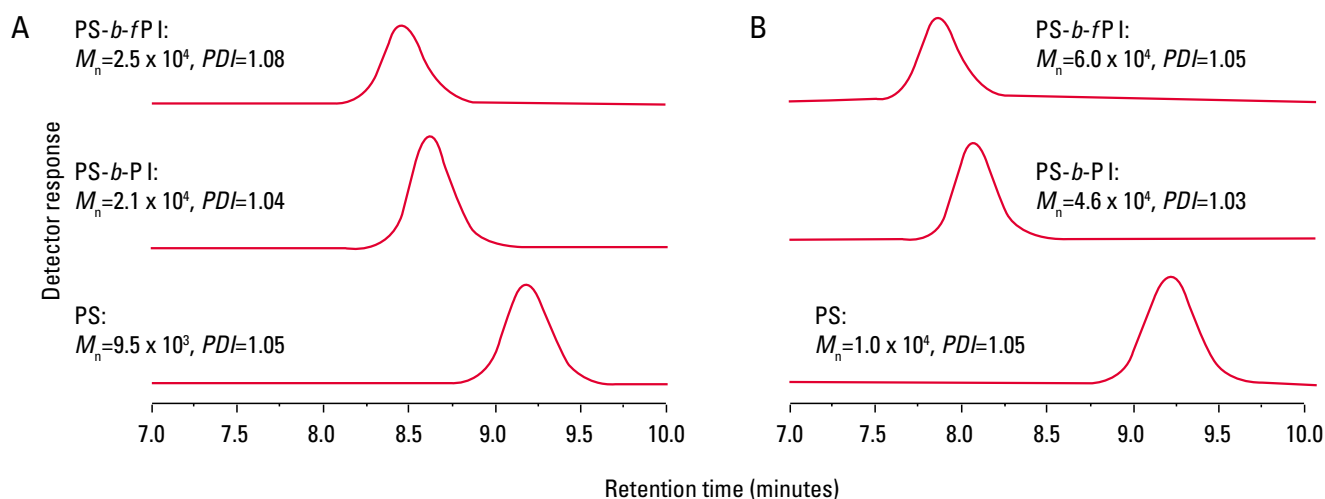

SULFONATED POLYSTYRENE-*b*-FLUORINATED POLYISOPRENE PRECURSOR SAMPLES

TSKgel SuperMultiporeHZ-M, 4.6 mm ID x 15 cm x 1; Samples: A. series 1, table 3 B, series 2, table 3; Mobile Phase: THF; Flow rate: 0.35 mL/min; Detection: RI; Temperature: 35°C Inj. vol.: 20 μ L